

Drop-In Drop-in bain-marie, with three wells (3 GN container capacity)

ITEM # _____

MODEL # _____

NAME # _____

SIS # _____

AIA # _____



341006 (D02H3)

* NOT TRANSLATED *

Main Features

- Electronic overheating protection.
- Designed to serve the food in gastronorm containers.
- Suitable for GN 1/1 containers with a maximum height of 200 mm.
- Precise temperature control and setting at 0,1°C .
- As standard the product comes with digitally controlled thermostat which is in line of HACCP norms and provides visual alarm as a warning of the increasing or decreasing temperatures.
- It is possible to transform one of the GNs to soup dispenser with the available accessory.
- CB and CE certified by a third party notified body.
- Designed to be positioned in flush installation providing improved cleanability and suitable for modern design installations.
- Available drop-in dimensions: 2, 3, 4 GN.
- Food introduced at the correct temperature maintains its core temperature according to Afnor Standards.
- Designed to work with both hot and cold water.
- Wells bottom are inclined to guarantee full well drainage.

Construction

- Heating elements connected to the well bottom include safety thermostat
- IPX4 water resistance certification.
- Electronic control with temperature display.
- Well in 304 AISI stainless steel with rounded corners to facilitate cleaning operations. The well is also equipped with a drain hole.

Sustainability



- Etched foil heating elements to maximize heat transmission for reduced warm-up times.
- 19mm thick rock wool isolated with galvanize sheet guarantees excellent well insulation to reduce energy dispersion.
- Equipped with separated GN 1/1 wells to minimize water and electricity usage allowing to operate only the needed wells. Each well can be switched on/off independently.

APPROVAL: _____

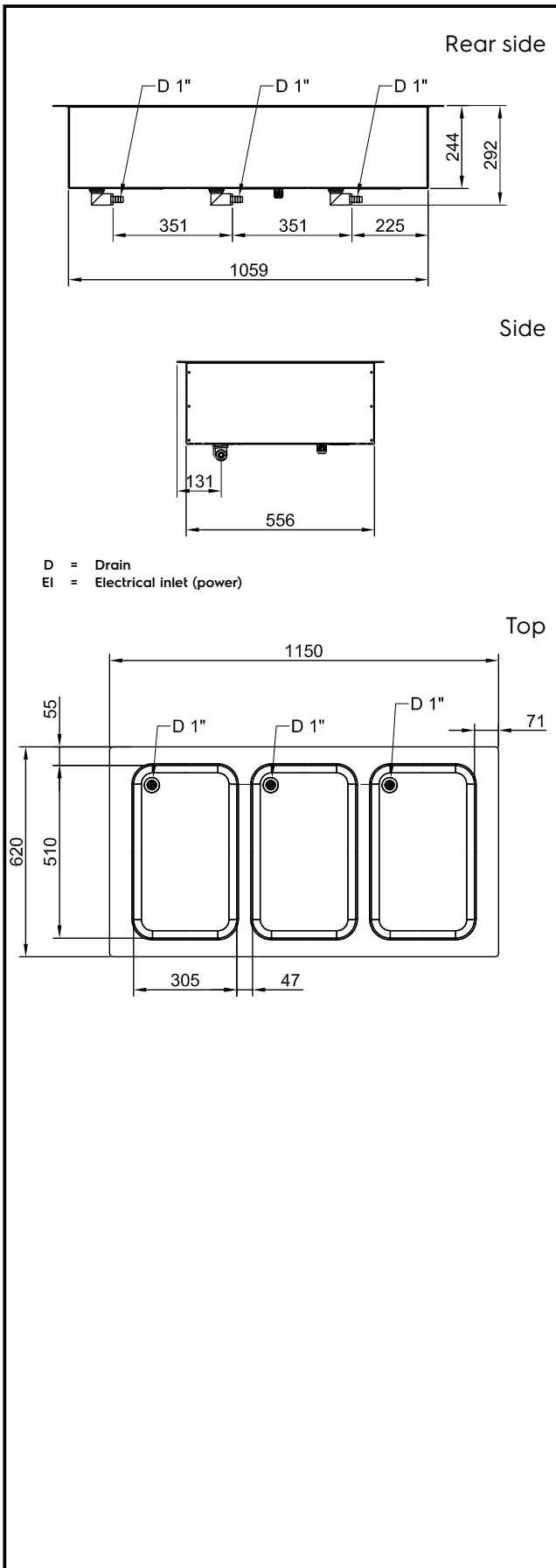

Electric

Supply voltage:

341006 (D02H3)

220-240 V/1N ph/50/60 Hz

Electrical power max.:

3.02 kW

Water:

Drain line size:

1"

Key Information:

External dimensions, Width: 1150 mm

External dimensions, Depth: 620 mm

External dimensions, Height: 260 mm

Net weight: 31.1 kg

Shipping weight: 55 kg

Shipping height: 720 mm

Shipping width: 670 mm

Shipping depth: 1190 mm

Shipping volume: 0.57 m³

Set temperature: +85 / +95 °C

Sustainability

Noise level:

0 dBA

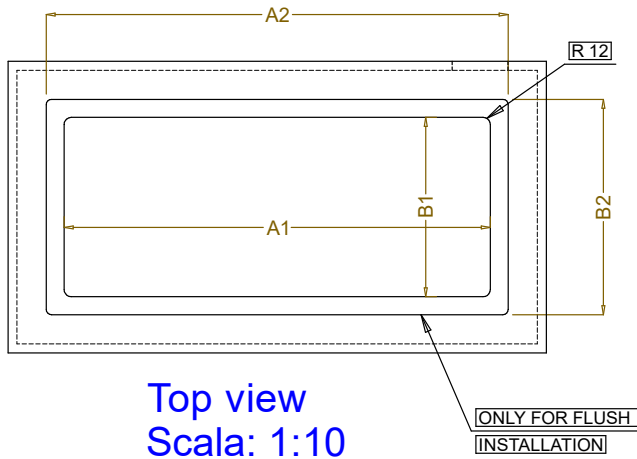
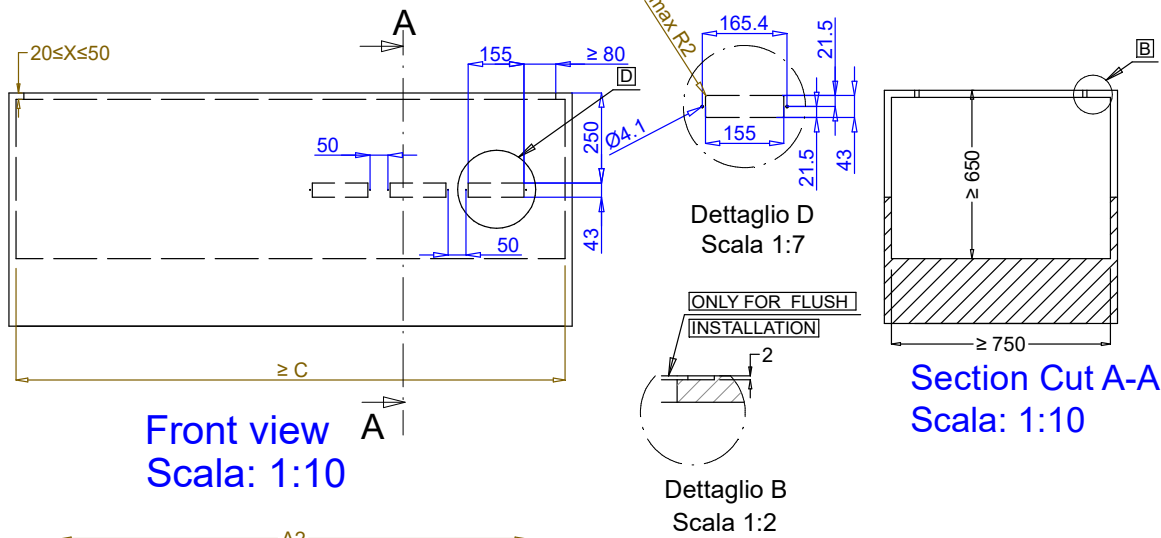

CAPACITY	CUTOUT		LOWERING FOR FLUSH INSTALLATION		C
	A1	B1	A2	B2	
2GN	730		804		910
3GN	1080	580	1154	624	1260
4GN	1430		1504		1610

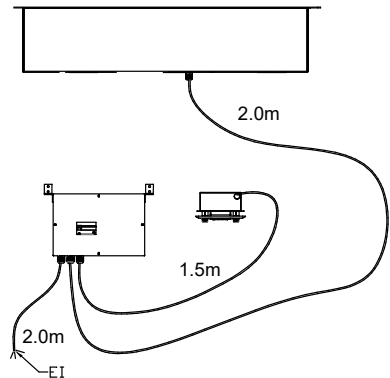
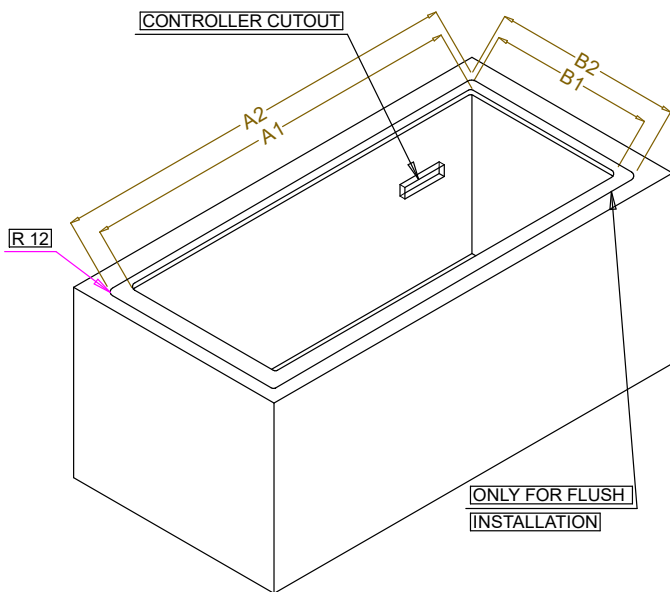

595T01M00 - WATER BAIN MARIE SEPARATED WELLS

Drop In

Drop-in bain-marie, with three wells (3 GN container capacity)

The company reserves the right to make modifications to the products without prior notice. All information correct at time of printing.